

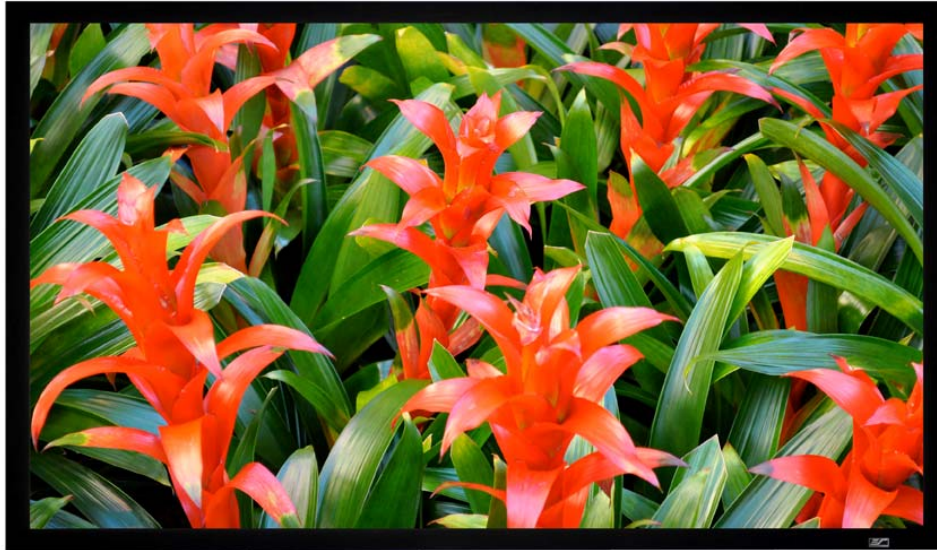

# **StarBright7**

## Fixed Frame Projection Screen

### User Guide



# Attention:

The StarBright7 screen material is composed of high quality sensitive multi-layer projection material.

**Please follow the pre-cautions below for proper care procedures and to prolong the life of your StarBright7.**

Failure to comply will result in voiding your warranty.

Avoid using any chemical compounds or harsh abrasives which will result in permanently damaging the screen material.

- 🔊 USE ONLY a soft non-abrasive cloth with mild soap and water to clean the screen material
- 🔊 DO NOT rub the cloth with force when cleaning to avoid permanently scratching the surface
- 🔊 DO NOT touch the screen surface with sharp objects
- 🔊 USE ONLY a soft feathered brush to remove dust

## Parts List

1. Frame Parts x 6 pcs (4 top frame pcs. + 2 side frame pcs)
2. Tension Rods x 6 pcs (4 top/bottom rods + 2 side rods)
3. StarBright7 Screen Material x 1 pc
4. Center joints x 2 pcs
5. Elbow Joints x4 pcs
6. Wall brackets x 2-3 pcs (depending on model)
7. Screws x 16 pcs
8. User Guide x 1 pc
9. Center Support Bar x 1-2 pcs (depending on model)
10. Support joiner x 2-4 pcs (depending on model)
11. Fix Plates x 30-90 pcs (depending on model)
12. Cotton gloves x 2

**Note: Please make sure all parts are included in your package before proceeding to assemble your Elite Screens fixed frame projection screen.**

## ASSEMBLING THE FRAME

1. Insert joint connector to horizontal frame piece and then fasten it with 2 screws

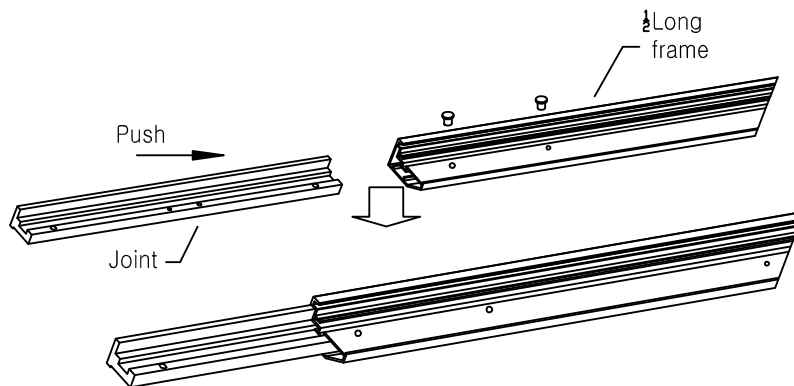

2. Insert the other horizontal frame piece to the joint connector and then fasten it with 2 screws.

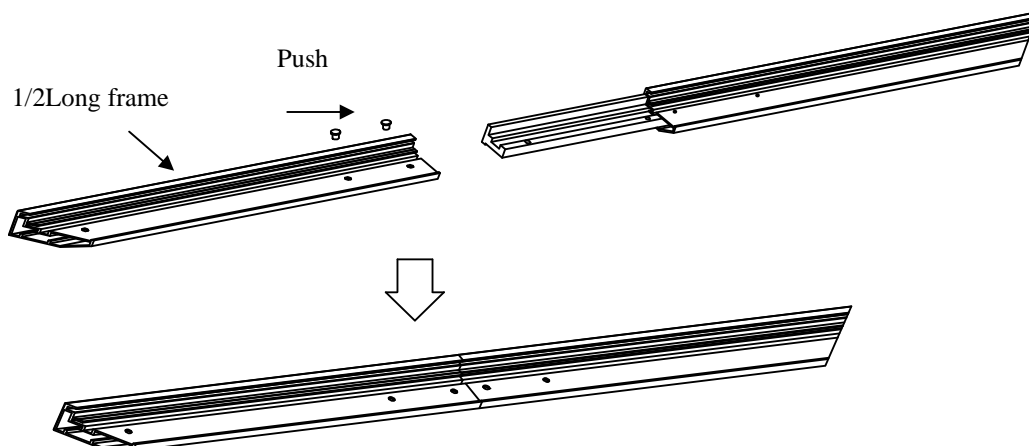

Please do not tighten the screws completely, to make sure the frame piece lines up correctly.

3. Insert both corner joint connectors into the long horizontal frame (see fig.1)

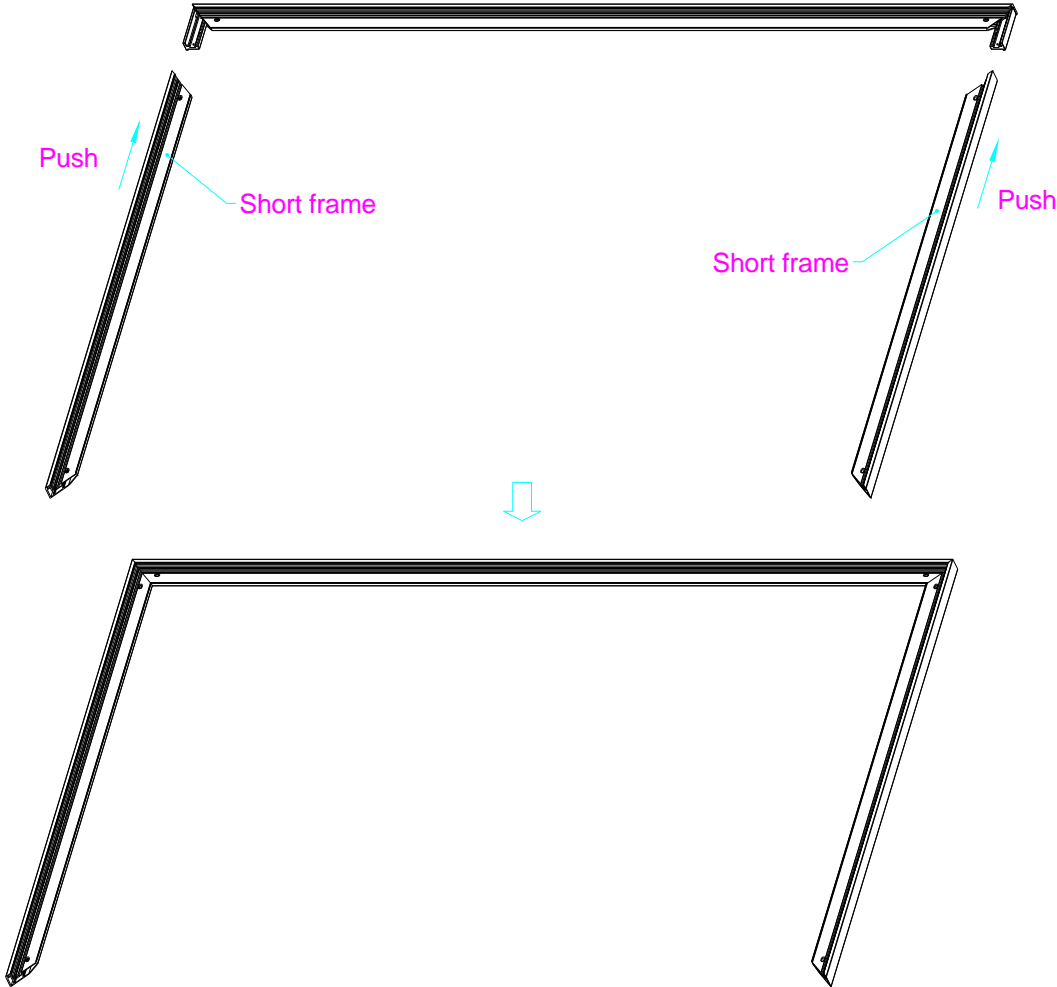
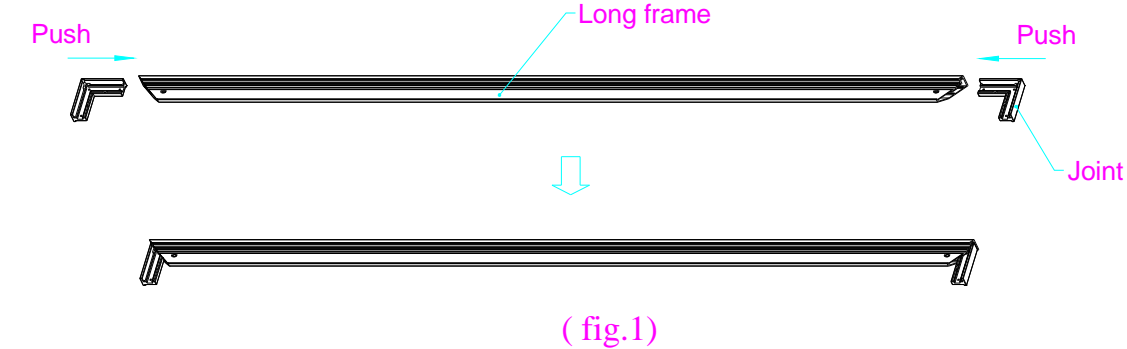

4. Join all four frame parts together following the steps showed below. (fig.2)

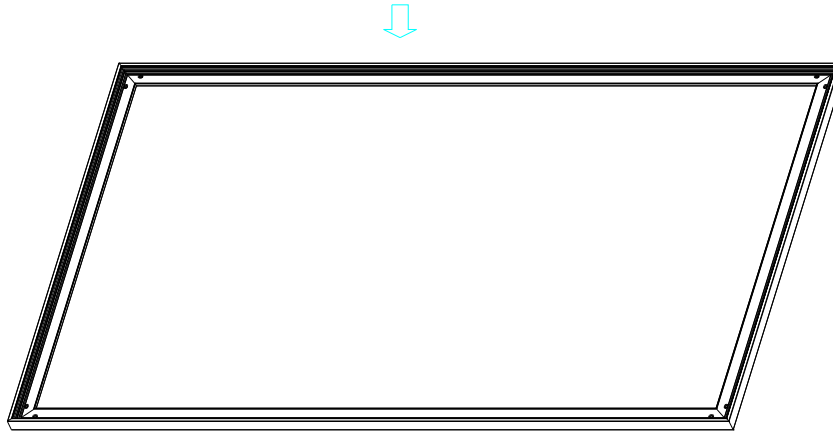
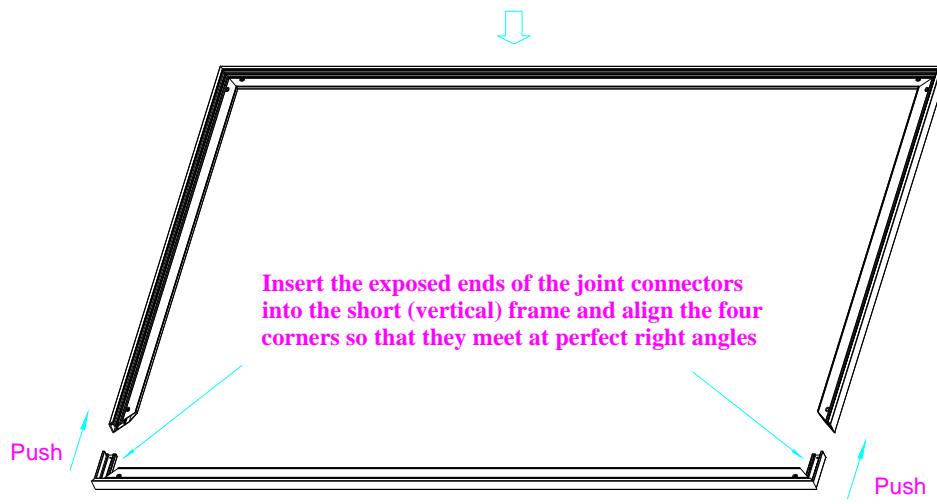

5. After making sure that all four corners join at right angles to form a perfect rectangle, fasten the four angles together by using the (x8) joint screws included. (see fig.3)

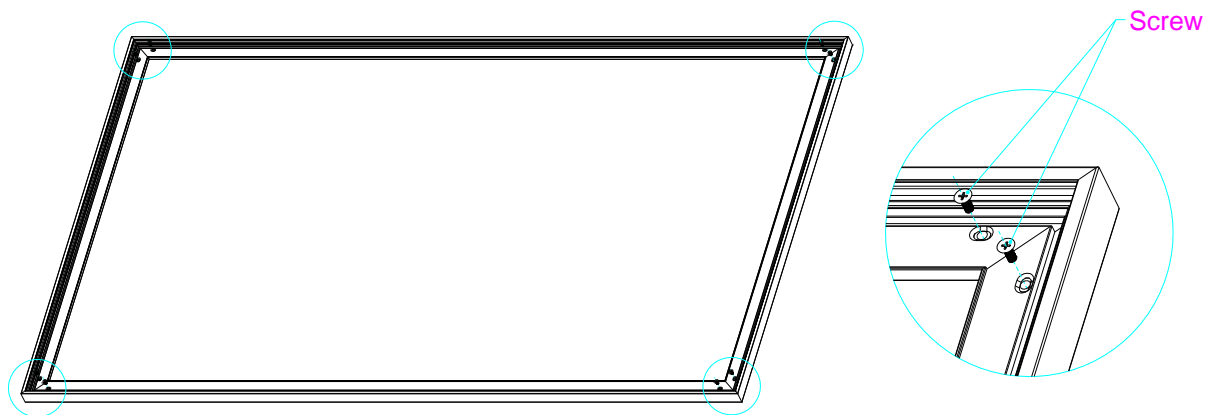

( fig.3 )

**\*\*Important: Read before handling material \*\***

The Starbright7 material is precision crafted to perform its role as a high gain, high contrast front projection surface. Because of this, it is very sensitive to how it is handled. When assembling the screen, please roll out the material slowly and carefully. It is easy to crease this material by grabbing, pinching, folding or otherwise handling it inappropriately. Instead of laying it out on a clean and level surface, it is better to unroll it to avoid damage. Please keep the material away from pets and children so that they do not accidentally tread on it.

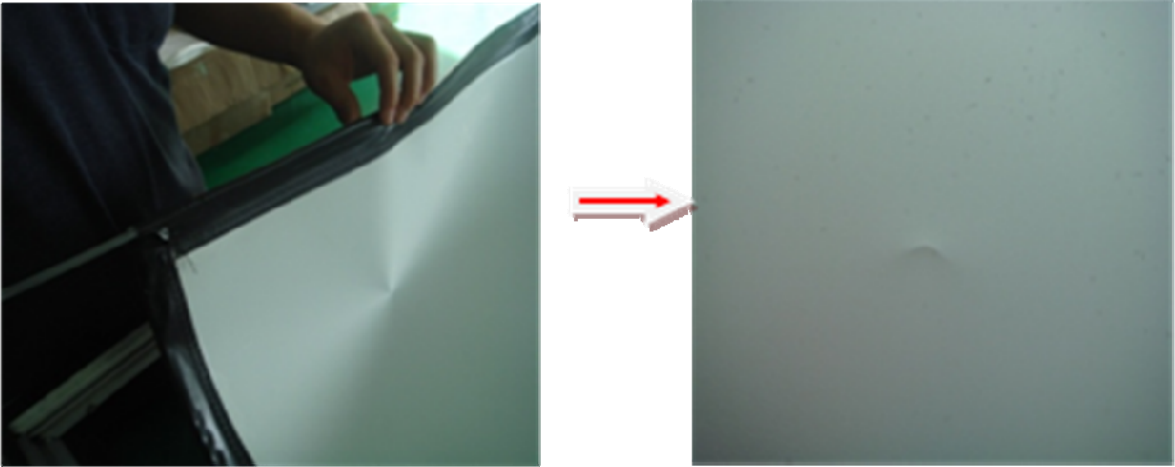

The photos above indicate how a simple twist in the material during the installation can cause permanent damage. Be extremely careful with your setup, read the instructions carefully and consult an Elite Screens service rep for any questions regarding the product assembly.

# Attaching the StarBright7 screen material to the frame

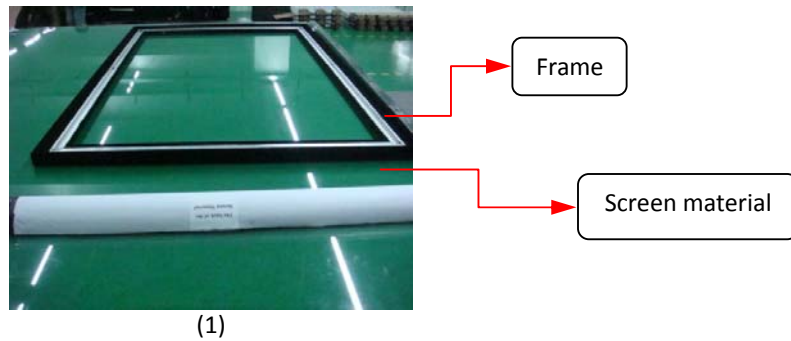

- Step1.** To prevent damage to the screen material, please put on the cotton gloves (included) and carefully lay out the screen and frame on a clean and dry surface.
- Step2.** Remove the protective film on the screen material.
- Step3.** Keep “The back of the Screen Material” tag and **face up** as shown in fig. (2).
- Step3.** Place the screen material on the back of the assembled frame as shown in fig. (3).
- Step4.** Carefully unfold the screen material and make it parallel with the frame as shown in fig. (4).

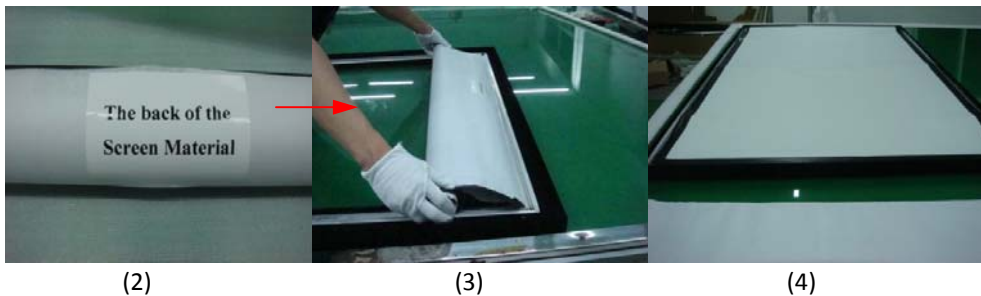

- Step5.** Remove the white paper very carefully as shown in fig. (5).

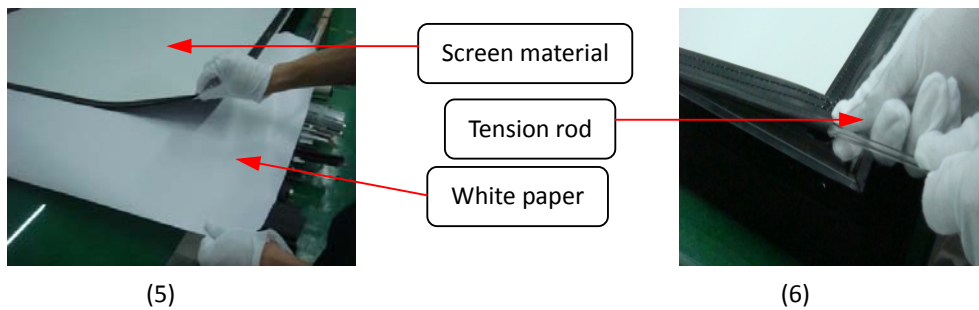

- Step6.** Insert the tension rods through the sleeves according to the length on each side of the screen and insert the tension rods into the grooves of each side on the back of the frame as shown in fig. (6).
- Step7.** Attach the fix plates to the frame in the position indicated by the red arrows on the back of the frame as shown in fig. (7).

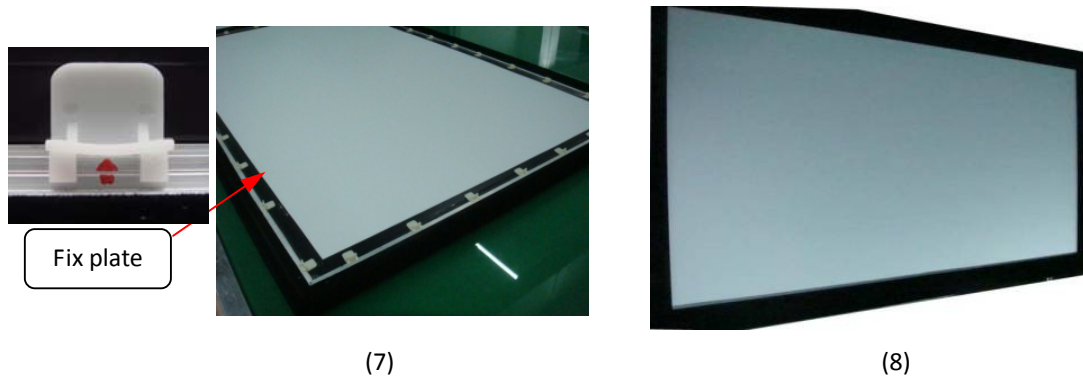

# CAUTION

**Please follow these instructions carefully to ensure proper maintenance and safety with your StarBright7 ez-Frame Screen**

1. When hanging the screen up, please make sure that no other objects such as power switches, outlets, furniture, ladders, windows, etc. occupy the space designated for your Fixed-Frame screen.
2. Regardless if the screen is hung on or installed into the wall, make sure that the proper mounting anchors are used and that the weight is supported appropriately by a strong and structurally sound surface just as any large and heavy picture frame should.  
*(Please consult a home improvement specialist for the best advice on installation)*
3. Frame parts are made of high quality velour-surfaced aluminum and should be handled with care.
4. When not in use, cover over the screen with a furniture sheet to protect it from dust, dirt, grime, paint or any other impurities.
5. Never attempt to use any solutions, chemicals or abrasive cleaners on the screen surface.
6. In order to avoid damaging the screen, avoid touching it directly with your fingers, tools or any other sharp or abrasive objects.
7. Spare Parts should be placed out of reach of small children in accordance with household safety guidelines.



## Center Support Bar

1. Insert the support joiner into each side of the center support bar to complete assembly.

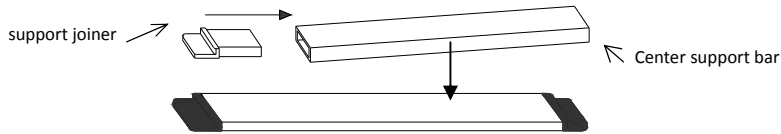

2. Insert the Center Support Bar into the groove on the back of the frame with the bottom end near the approximate center point of the frame and place it in at an angle so that both ends of the bar are in alignment with the groove as show below.

3. Slide the top end of the bar into the top center point location to complete center support bar installation. **This will provide added stability to your frame and added tension to the material.**

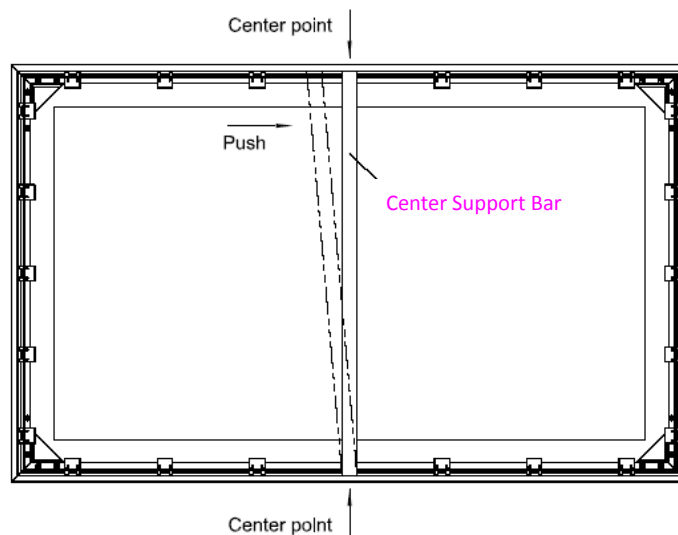

## INSTALLATION

1. Locate your desired installation location with a stud finder (recommended) and mark the drill-hole area of where the screen is to be installed.
2. Drill a hole with the proper bit size according to the wood screws included.
3. Line up the small wall brackets with the drilled holes on the installation location and screw them in using a Philips screwdriver.
4. Position the fixed frame screen onto the top wall brackets as shown in **fig. 1** and push down at the center of the bottom frame rail to hook into the lower wall bracket.

Method 1 (smaller than 121" diagonal)

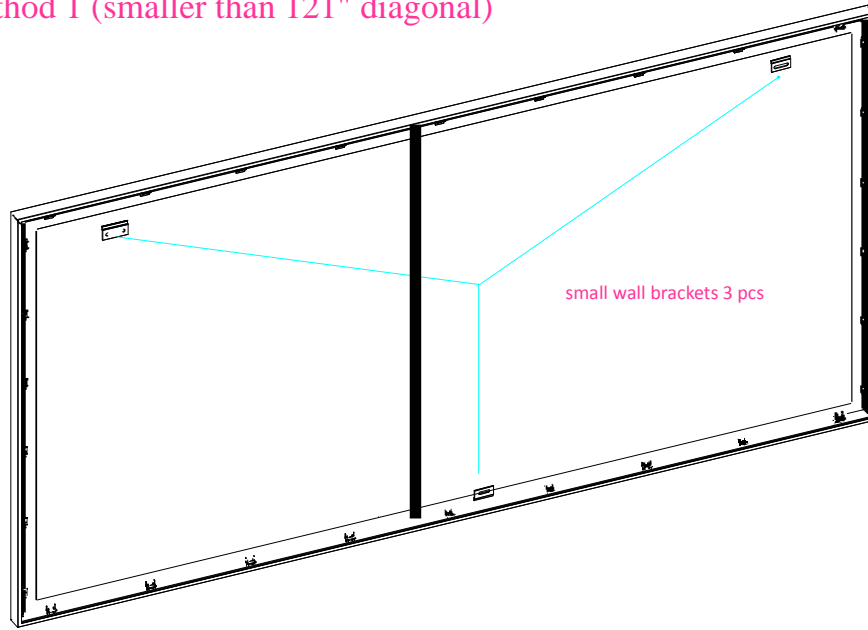

Method 2 (larger than 121" diagonals)

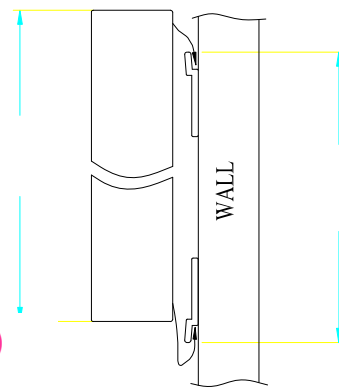
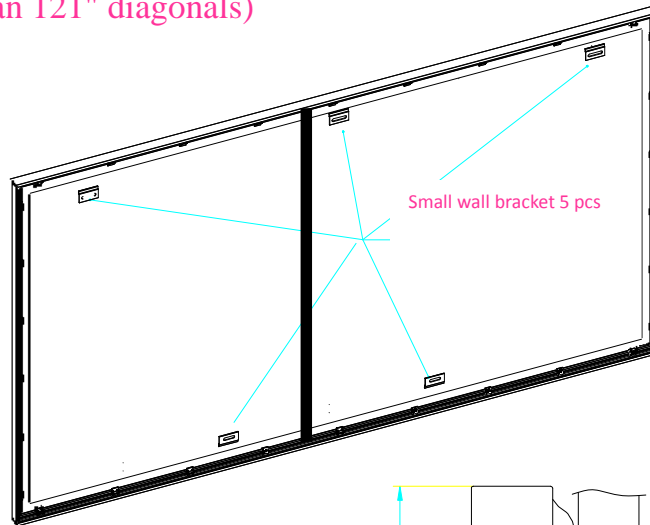

(Fig. 1)

Unit: mm							
Model	Screen Diag/Aspect Ratio	Overall Width (A)	View Width (A1)	Overall Height (B)	View Height (B1)	Frame Width (C)	Frame Height (D)
R76H-G7	76"(16:9)	1802	1682	1066	946	60	40
R88H-G7	88"(16:9)	2068	1948	1216	1096	60	40
R103H-G7	103"(16:9)	2400	2280	1403	1283	60	40
R121H-G7	121"(16:9)	2799	2679	1627	1507	60	40
Unit: inch							
Model	Screen Diag/Aspect Ratio	Overall Width (A)	View Width (A1)	Overall Height (B)	View Height (B1)	Frame Width (C)	Frame Height (D)
R76H-G7	76"(16:9)	70.9	66.2	42.0	37.2	2.4	1.6
R88H-G7	88"(16:9)	81.4	76.7	47.9	43.1	2.4	1.6
R103H-G7	103"(16:9)	94.5	89.8	55.2	50.5	2.4	1.6
R121H-G7	121"(16:9)	110.2	105.5	64.1	59.3	2.4	1.6

\*Measurement dimensions are intended as a reference only and subject to change without notice

Note: Data Error may be  $\pm 1$ "

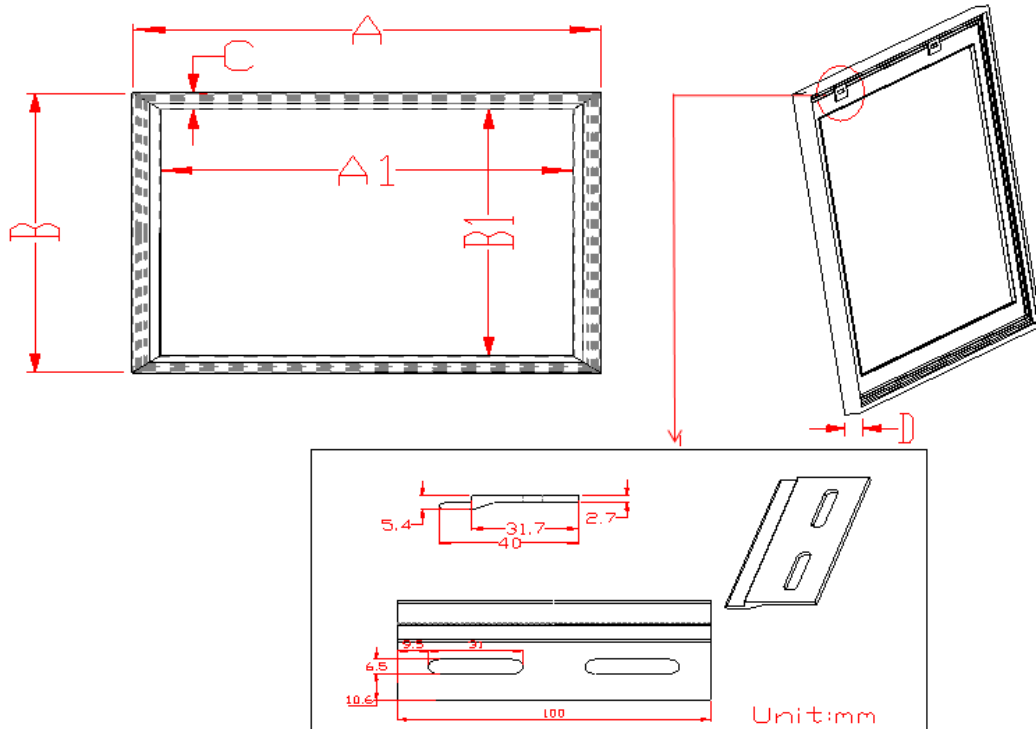

# Warranty Policy

- Two (2) year warranty on parts and labor from defects in workmanship from purchase date as follows.
- Each party will be responsible for one way shipping during the warranty return period.
- DOA (Defective on Arrival): Must be reported within 7 business days of receipt.
- An RMA (Return Merchandise Authorization) number must be issued in order to process a replacement or authorize a warranty repair. Elite Screens will replace the DOA (Defective on Arrival) unit with a brand new replacement \*(see exceptions below) after the DOA unit is received and/or confirmed defective. Once the product is received, Elite Screens will send out a new \*unit to the customer by ground service (subject to inventory availability). Should a problem be reported after the 7-day grace period, the item must be shipped to us for warranty repair.
- Missing Parts must be reported within the 7-day (DOA) grace period. If reported after 7 days, customer will only be responsible for shipping and handling fees. If reported after 30 days of receipt, customer is responsible for cost of the parts and shipping & handling fees.
- DO NOT return any unauthorized items to Elite Screens, as they will be refused at shipper's expense. The RMA number must be included on the outside label of your shipping box and shipping documents. Our warehouse is not authorized to accept returns without an RMA number on the shipping label. RMA numbers are valid for 45 days from the date of issue.

\*A new or refurbished replacement will be sent out to the customer depending on the type of purchase (new or refurbished) or based on stock availability.

For Warranty and Service requests please fill out a RMA /Service Form at:

[http://www.elitescreens.com/service\\_formhtm](http://www.elitescreens.com/service_formhtm).

Please Visit this link for full Warranty information:

<http://www.elitescreens.com/service.htm>

For Customer Service and Technical questions, please contact Elite Screens at:

Telephone:(877)-511-1211 Fax:(562)-483-8498

Register your warranty at [www.elitescreens.com/register.html](http://www.elitescreens.com/register.html)

**US & Canada Tech Support & Warranty Claim**

Please contact us at [service@elitescreens.com](mailto:service@elitescreens.com) or call +1 877-511-1211 #3 Service

**Europe Tech Support & Warranty Claim**

Please contact us at [service@elitescreens.eu](mailto:service@elitescreens.eu) or call +49-(0) 40-30392958

**Asia or China Tech Support & Warranty Claim**

Please contact us at [service@elitescreens.com.cn](mailto:service@elitescreens.com.cn) or call +86-(0) 755-8461-7989

**Taiwan Tech Support & Warranty Claim**

Please contact us at [service@elitescreens.com.tw](mailto:service@elitescreens.com.tw) or call +886-(02)2747-8979

**America: Elite Screens Inc**

16410 Manning Way, Cerritos, CA 90703 USA Tel: 877-511-

1211 Fax: 562-483-8498

[info@elitescreens.com](mailto:info@elitescreens.com)

[www.elitescreens.com](http://www.elitescreens.com)

**Europe: Elite Screens Europe GmbH**

Lübecker Straße, 122087 Hamburg, Germany

Tel: +49-40-30392494 Fax: +49-40-49219200

[info@elitescreens.eu](mailto:info@elitescreens.eu)

[www.elitescreens.eu](http://www.elitescreens.eu)

**Asia: Elite Screens China Ltd.**

Longxi Duimianling Industry Zone Longcheng

Longgang District, ShenZhen GuangDong, China

Tel: +86-(0)755-8461-7989 Fax: +86-(0)755-8461-7669

[info@elitescreens.com.cn](mailto:info@elitescreens.com.cn)

[www.elitescreens.com.cn](http://www.elitescreens.com.cn)

**Taiwan:**

**Elite Screens Taiwan Corp.**

1F. No. 38 Alley 22 Lane 66 Sec. 5 Nanjing E. Rd. Songshan Distrit. Taipei City 105, Taiwan

Tel: +886-(02)2747-8979 Fax: +886-(02)2747-8978

[info@elitescreens.com.tw](mailto:info@elitescreens.com.tw)

[www.elitescreens.com.tw](http://www.elitescreens.com.tw)

**Email contacts:**

**Latin America Contact:**

[erik.garcia@elitescreens.com](mailto:erik.garcia@elitescreens.com)

**East Asia Contact:**

[info.ea@elitescreens.com](mailto:info.ea@elitescreens.com)

**India Contact:**

[info.india@elitescreens.com](mailto:info.india@elitescreens.com)

**Japan Contact:**

[info.japan@elitescreens.com](mailto:info.japan@elitescreens.com)